

Crestron **TPS-6X-FP**  
and **TPS-6X-FP-NB**  
Bezels for the TPS-6X Series

---

Installation Guide



---

## Introduction

The TPS-6X-FP and TPS-6X-FP-NB are replacements for the bezel that comes installed on Crestron® TPS-6X Series wireless touchpanels. The TPS-6X-FP is a button bezel with custom engraving, sold separately. The TPS-6X-FP-NB is a no-button bezel that comes with the TPS-6X Series touchpanels and can be used in place of the button bezel with default engraving, which comes installed on the touchpanel.

---

## Installation

Perform the following procedure to remove the existing bezel and install the new bezel onto the touchpanel. A #1 Phillips screwdriver is required. Refer to the illustration below.

1. Remove power from the touchpanel, slide the battery switch on the rear to the OFF (down) position and place the touchpanel face down on a clean, padded work surface.
2. Remove the four screws that secure the front bezel to the touchpanel and return the unit to its normal, face-up, position. (Use care and hold the bezel to the rest of the panel. If the bezel separates from the rest of the touchpanel while rotating the unit to its normal position, the internal parts of the panel may spill out.)

*Bottom View Showing Battery Switch and Screw Locations*

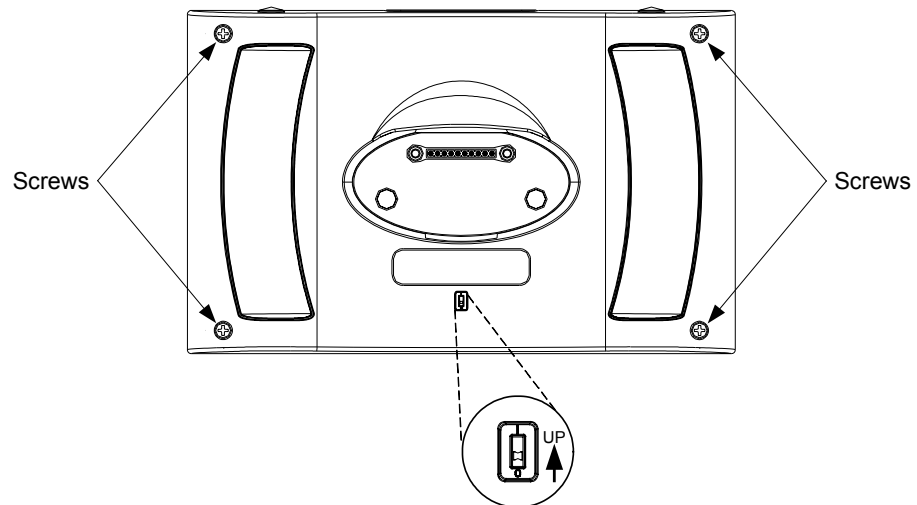

3. When the touchpanel is in its normal, face-up, position, lift the bezel from the touchpanel.
4. Position the new bezel over the exposed touchpanel, ensuring the ribbon cables remain tucked in place and the fiber optic cables remain inboard of the posts located next to each of the bottom screw holes.
5. Hold the bezel to the rest of the touchpanel and carefully rotate the entire panel onto its face once more.
6. Reinstall the four screws to secure the bezel to the touchpanel. Tighten the screws, being careful not to strip the threads.
7. Re-connect power, slide the battery switch on the rear to the ON (up) position.

---

## Return and Warranty Policies

### Merchandise Returns / Repair Service

1. No merchandise may be returned for credit, exchange or service without prior authorization from CRESTRON. To obtain warranty service for CRESTRON products, contact an authorized CRESTRON dealer. Only authorized CRESTRON dealers may contact the factory and request an RMA (Return Merchandise Authorization) number. Enclose a note specifying the nature of the problem, name and phone number of contact person, RMA number and return address.
2. Products may be returned for credit, exchange or service with a CRESTRON Return Merchandise Authorization (RMA) number. Authorized returns must be shipped freight prepaid to CRESTRON, 6 Volvo Drive, Rockleigh, N.J. or its authorized subsidiaries, with RMA number clearly marked on the outside of all cartons. Shipments arriving freight collect or without an RMA number shall be subject to refusal. CRESTRON reserves the right in its sole and absolute discretion to charge a 15% restocking fee plus shipping costs on any products returned with an RMA.
3. Return freight charges following repair of items under warranty shall be paid by CRESTRON, shipping by standard ground carrier. In the event repairs are found to be non-warranty, return freight costs shall be paid by the purchaser.

### CRESTRON Limited Warranty

CRESTRON ELECTRONICS, Inc. warrants its products to be free from manufacturing defects in materials and workmanship under normal use for a period of three (3) years from the date of purchase from CRESTRON, with the following exceptions: disk drives and any other moving or rotating mechanical parts, pan/tilt heads and power supplies are covered for a period of one (1) year; touchscreen display and overlay components are covered for 90 days; batteries and incandescent lamps are not covered.

This warranty extends to products purchased directly from CRESTRON or an authorized CRESTRON dealer. Purchasers should inquire of the dealer regarding the nature and extent of the dealer's warranty, if any.

CRESTRON shall not be liable to honor the terms of this warranty if the product has been used in any application other than that for which it was intended or if it has been subjected to misuse, accidental damage, modification or improper installation procedures. Furthermore, this warranty does not cover any product that has had the serial number altered, defaced or removed.

This warranty shall be the sole and exclusive remedy to the original purchaser. In no event shall CRESTRON be liable for incidental or consequential damages of any kind (property or economic damages inclusive) arising from the sale or use of this equipment. CRESTRON is not liable for any claim made by a third party or made by the purchaser for a third party.

CRESTRON shall, at its option, repair or replace any product found defective, without charge for parts or labor. Repaired or replaced equipment and parts supplied under this warranty shall be covered only by the unexpired portion of the warranty.

Except as expressly set forth in this warranty, CRESTRON makes no other warranties, expressed or implied, nor authorizes any other party to offer any warranty, including any implied warranties of merchantability or fitness for a particular purpose. Any implied warranties that may be imposed by law are limited to the terms of this limited warranty. This warranty statement supersedes all previous warranties.

#### Trademark Information

*All brand names, product names and trademarks are the sole property of their respective owners. Windows is a registered trademark of Microsoft Corporation. Windows95/98/Me/XP/Vista/7 and WindowsNT/2000 are trademarks of Microsoft Corporation.*



**Crestron Electronics, Inc.**  
15 Volvo Drive Rockleigh, NJ 07647  
Tel: 888.CRESTRON  
Fax: 201.767.7576  
[www.crestron.com](http://www.crestron.com)

---

**Installation Guide – DOC. 6737B**  
**(2022189)**  
**02.10**  
Specifications subject to  
change without notice.